

## Replacing the drum unit

Part Number QPDR89

A new drum unit can print approximately 30,000 Letter or A4 size single-sided pages.

### Note

- There are many factors that determine the actual drum life, such as the temperature, humidity, type of paper, type of toner used and so on. Under ideal conditions, the average drum life is estimated at approximately 30,000 pages. The actual number of pages that your drum will print may be significantly less than this estimate. Because we have no control over the many factors that determine the actual drum life, we cannot guarantee a minimum number of pages that will be printed by your drum.
- For best performance, use only genuine Brother toner. The machine should be used only in a clean, dust-free environment with adequate ventilation.
- Printing with a non-Brother drum unit may reduce not only the print quality but also the quality and life of the machine itself. Warranty coverage does not apply to problems caused by the use of a non-Brother drum unit.

## Drum Error



The corona wire has become dirty. Clean the corona wire in the drum unit. (See *Cleaning the corona wire* >> page 45.)

If you cleaned the corona wire and **Drum Error** was not cleared then the drum unit is at the end of its life. Replace the drum unit with a new one.

## Replace Parts Drum

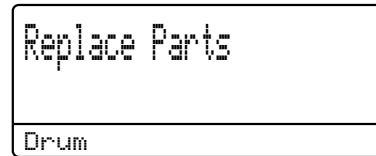

The drum unit has exceeded its rated life. Please replace the drum unit with a new one. We recommend a genuine Brother drum unit be installed at this time.

After replacement, reset the drum counter by following the instructions included with the new drum unit. (See *Resetting the drum counter* >> page 51.)

## Drum Stop



We cannot guarantee the print quality. Please replace the drum unit with a new one. We recommend a genuine Brother drum unit be installed at this time.

After replacement, reset the drum counter by following the instructions included with the new drum unit. (See *Resetting the drum counter* >> page 51.)

## Replacing the drum unit

### ! Important

- While removing the drum unit, handle it carefully because it may contain toner. If toner scatters on your hands or clothes, immediately wipe or wash it off with cold water.
- Every time you replace the drum unit, clean the inside of the machine. (See *Advanced User's Guide: Cleaning and checking the machine.*)
- Wait to unpack the new drum unit immediately before you put it in the machine. Exposure to direct sunlight or room light may damage the drum unit.

- 1 Leave the machine turned on for 10 minutes for the internal fan to cool the extremely hot parts inside the machine.
- 2 Press the front cover release button and then open the front cover.

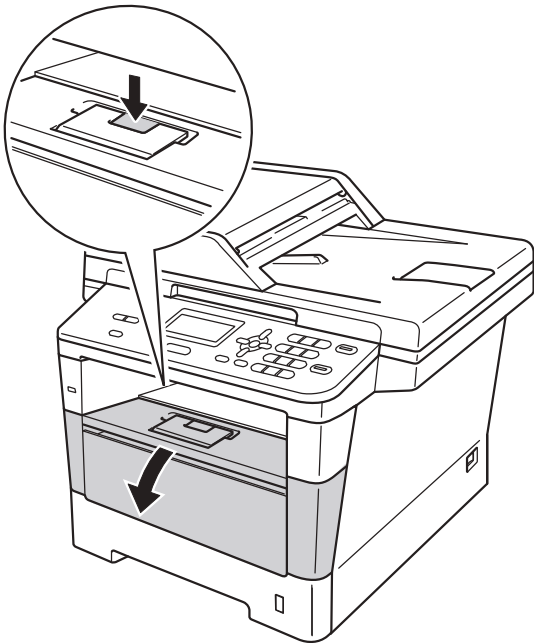

- 3 Take out the drum unit and toner cartridge assembly.

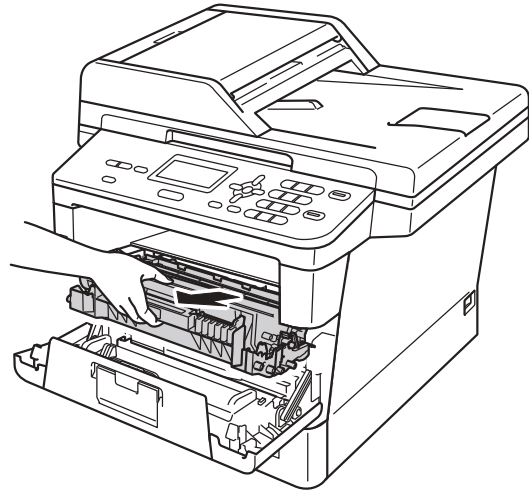

### ! WARNING

#### ! HOT SURFACE

After you have just used the machine, some internal parts of the machine will be extremely hot. Wait for the machine to cool down before you touch the internal parts of the machine.

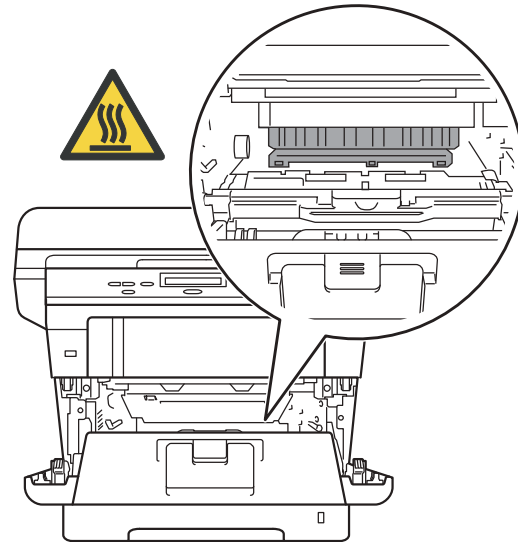

**! Important**

- We recommend that you place the drum unit and toner cartridge assembly on a clean, flat surface with a piece of disposable paper underneath it in case you accidentally spill or scatter toner.
- To prevent damage to the machine from static electricity, **DO NOT** touch the electrodes shown in the illustration.

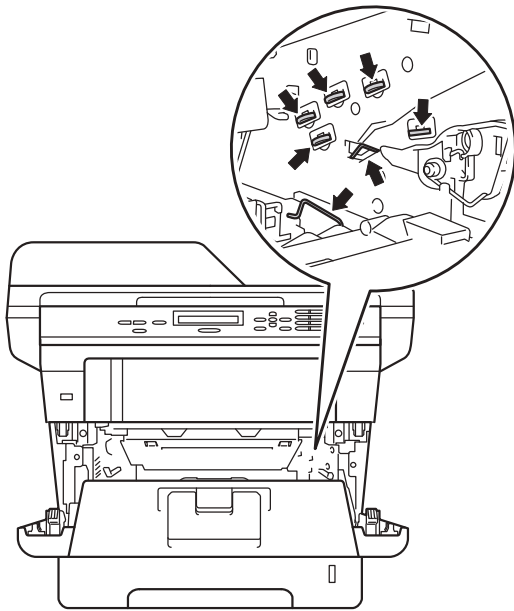

- 4** Push down the green lock lever and take the toner cartridge out of the drum unit.

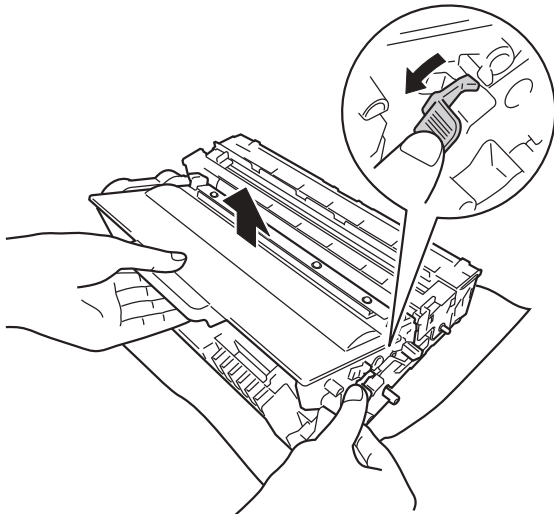

**! WARNING**



- **DO NOT** put a toner cartridge or a toner cartridge and drum unit assembly into a fire. It could explode, resulting in injuries.
- **DO NOT** use flammable substances, any type of spray, or an organic solvent/liquid containing alcohol or ammonia to clean the inside or outside of the machine. Doing so could cause a fire or electrical shock. Instead, use only a dry, lint-free cloth.

(See Product Safety Guide: *To use the product safely.*)



## ! Important

- Handle the toner cartridge carefully. If toner scatters on your hands or clothes, immediately wipe or wash it off with cold water.
- To avoid print quality problems, DO NOT touch the shaded parts shown in the illustrations.

### <Toner cartridge>

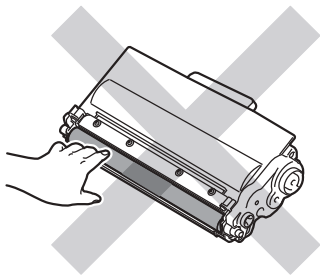

### <Drum unit>

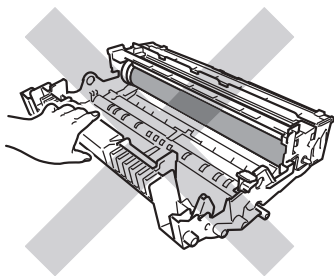

- We recommend that you place the toner cartridge on a clean, flat, level, stable surface with a sheet of disposable paper or cloth underneath it in case you accidentally spill or scatter toner.

## 📝 Note

- Be sure to seal up the used drum unit tightly in a suitable bag so that toner powder does not spill out of the drum unit.
- Go to <http://www.brother.com/original/index.html> for instructions on how to return your used consumable items to the Brother collection program. If you choose not to return your used consumable, please discard the used consumable according to local regulations, keeping it separate from domestic waste. If you have questions, call your local waste disposal office.

5. Unpack the new drum unit.
6. Put the toner cartridge firmly into the new drum unit until you hear it lock into place. If you put the cartridge in correctly, the green lock lever will lift automatically.

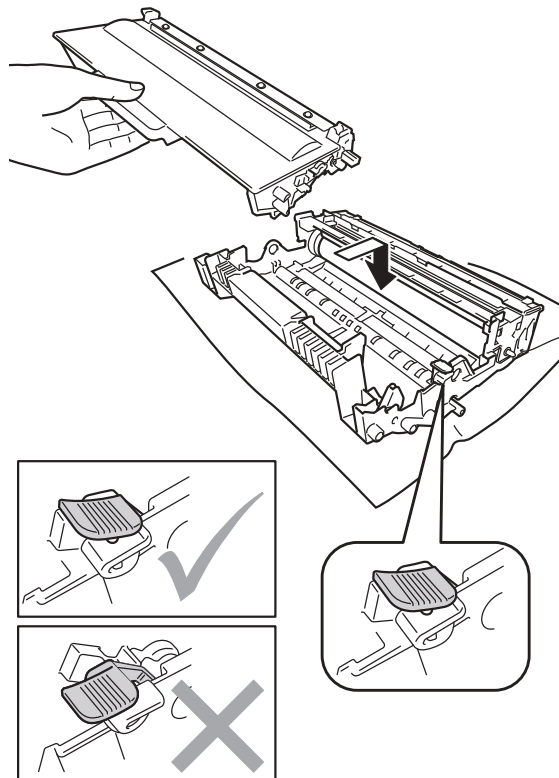



### Note

Make sure that you put in the toner cartridge correctly or it may separate from the drum unit.

- 7 Put the drum unit and toner cartridge assembly back into the machine. Do not close the front cover of the machine.

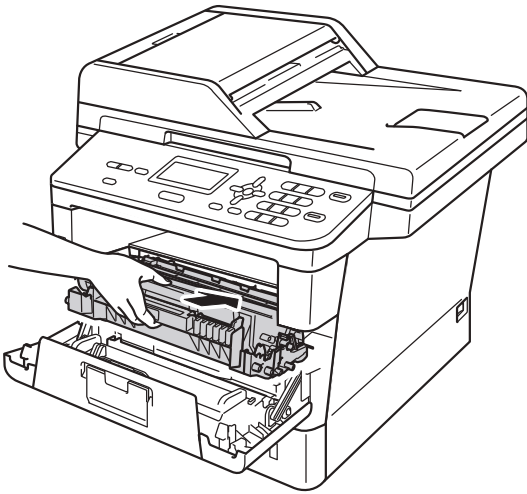

A

### Resetting the drum counter

When you replace a drum unit with a new one, you need to reset the drum counter by completing the following steps:



### Important

Do not reset the drum counter when you only replace the toner cartridge.

- 1 With the front cover still open, press **Clear**.

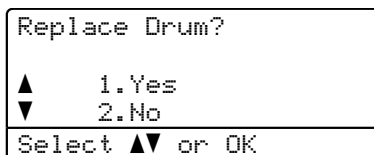

- 2 To confirm you are installing a new drum, press **1**.
- 3 When the LCD shows `Accepted`, close the front cover of the machine.